

6 5 4 3 2 1

D  
C  
B  
A

D  
C  
B  
A

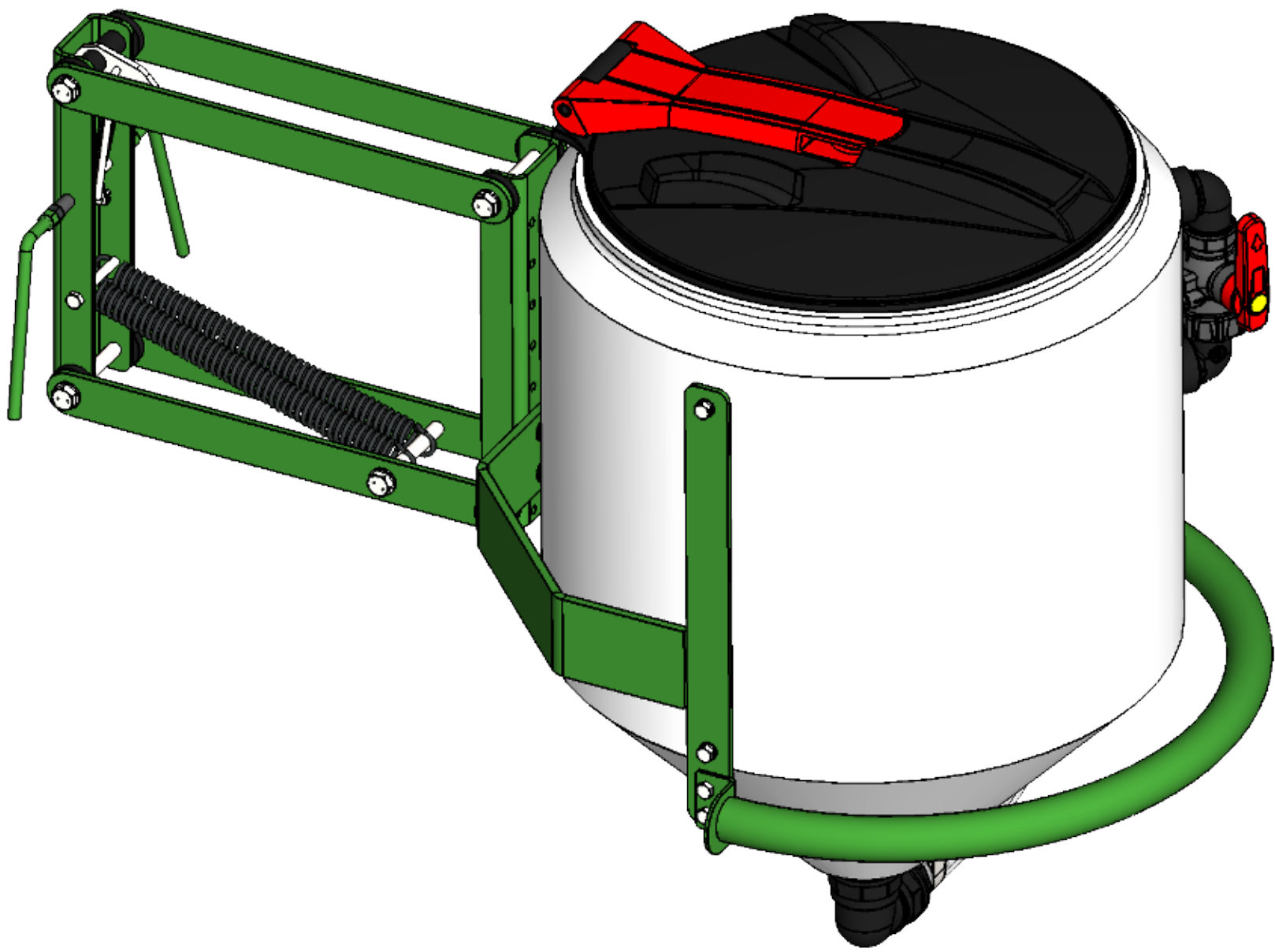

**TSI Beacon**   
 TIME SAVER INDUSTRIES

PO BOX 16, BEACON WA 6472  
 WEBSITE: [www.scudagcem.com.au](http://www.scudagcem.com.au)  
 E-MAIL: [sales@scudagchem.com.au](mailto:sales@scudagchem.com.au)  
 Mobile: 0428 861 119

THIS DRAWING AND ALL INFORMATION CONTAINED THEREON ARE THE EXCLUSIVE PROPERTY OF TSI BEACON.  
 UNLESS SPECIFICALLY NOTED, THIS DRAWING AND ITEMS SHOWN ON THIS DRAWING ARE SUBJECT TO CHANGE AT ANY TIME.

MATERIAL:  
 Material <not specified>  
 WEIGHT: 29.0 kg

DESCRIPTION  
 SCUD Tank 100 with DDL800

PART NUMBER  
 ST100BHDL800

REV

DO NOT SCALE DRAWING SHEET 1 OF 3

6 5 4 3 2 1

6

5

4

3

2

1

ITEM NO.	DESCRIPTION	PartNo	Qty
1	Drop Down Leg 800	DDL800	1
2	SCUD Tank 100 with Bracket and Handle	ST100BH	1
3	Hex Bolt 5/16x3/4 G316	B001-10020	4
4	FLAT WASHER 5/16 x 3/4 G316	K074-10024	4
5	Nylon Lock Nut 5/16 G316	D056-10000	4

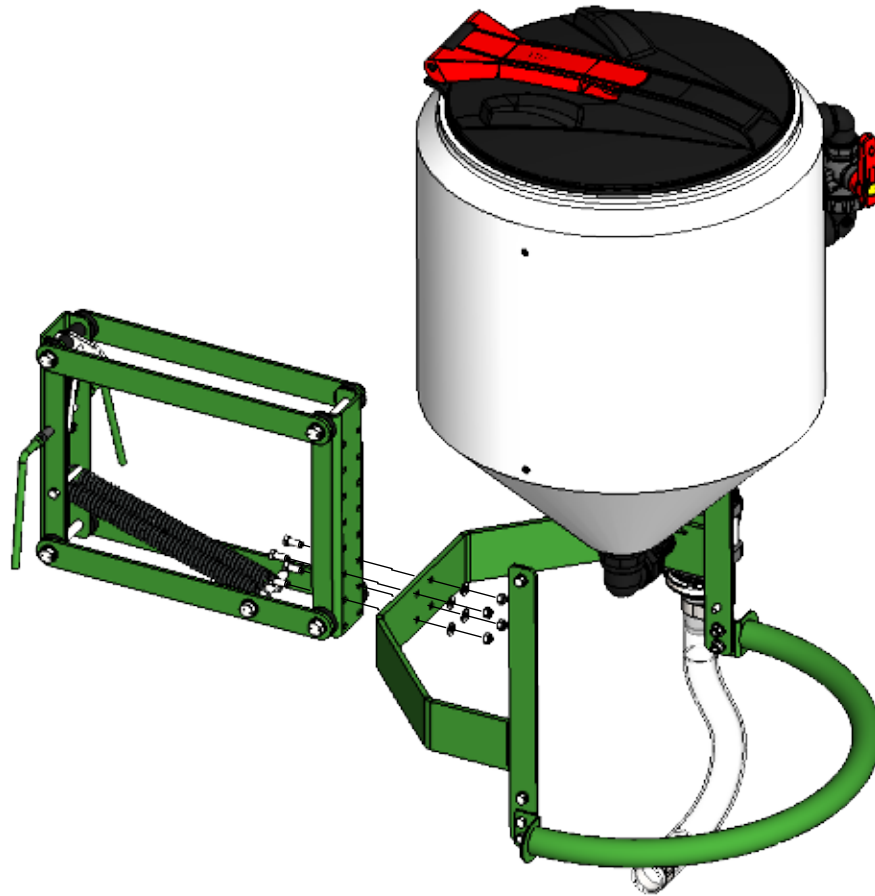

**TSI Beacon**   
TIME SAVER INDUSTRIES

PO BOX 16, BEACON WA 6472  
WEBSITE: [www.scudagcem.com.au](http://www.scudagcem.com.au)  
E-MAIL: [sales@scudagchem.com.au](mailto:sales@scudagchem.com.au)  
Mobile: 0428 861 119

THIS DRAWING AND ALL INFORMATION CONTAINED THEREON ARE THE EXCLUSIVE PROPERTY OF TSI BEACON.  
UNLESS SPECIFICALLY NOTED, THIS DRAWING AND ITEMS SHOWN ON THIS DRAWING ARE SUBJECT TO CHANGE AT ANY TIME.

MATERIAL:  
Material <not specified>  
WEIGHT: 29.0 kg

DESCRIPTION  
SCUD Tank 100 with DDL800

PART NUMBER  
ST100BHDL800

REV

DO NOT SCALE DRAWING SHEET 2 OF 3

6

5

4

3

2

1

D

D

C

C

B

B

A

A

6 5 4 3 2 1

D  
C  
B  
A

D  
C  
B  
A

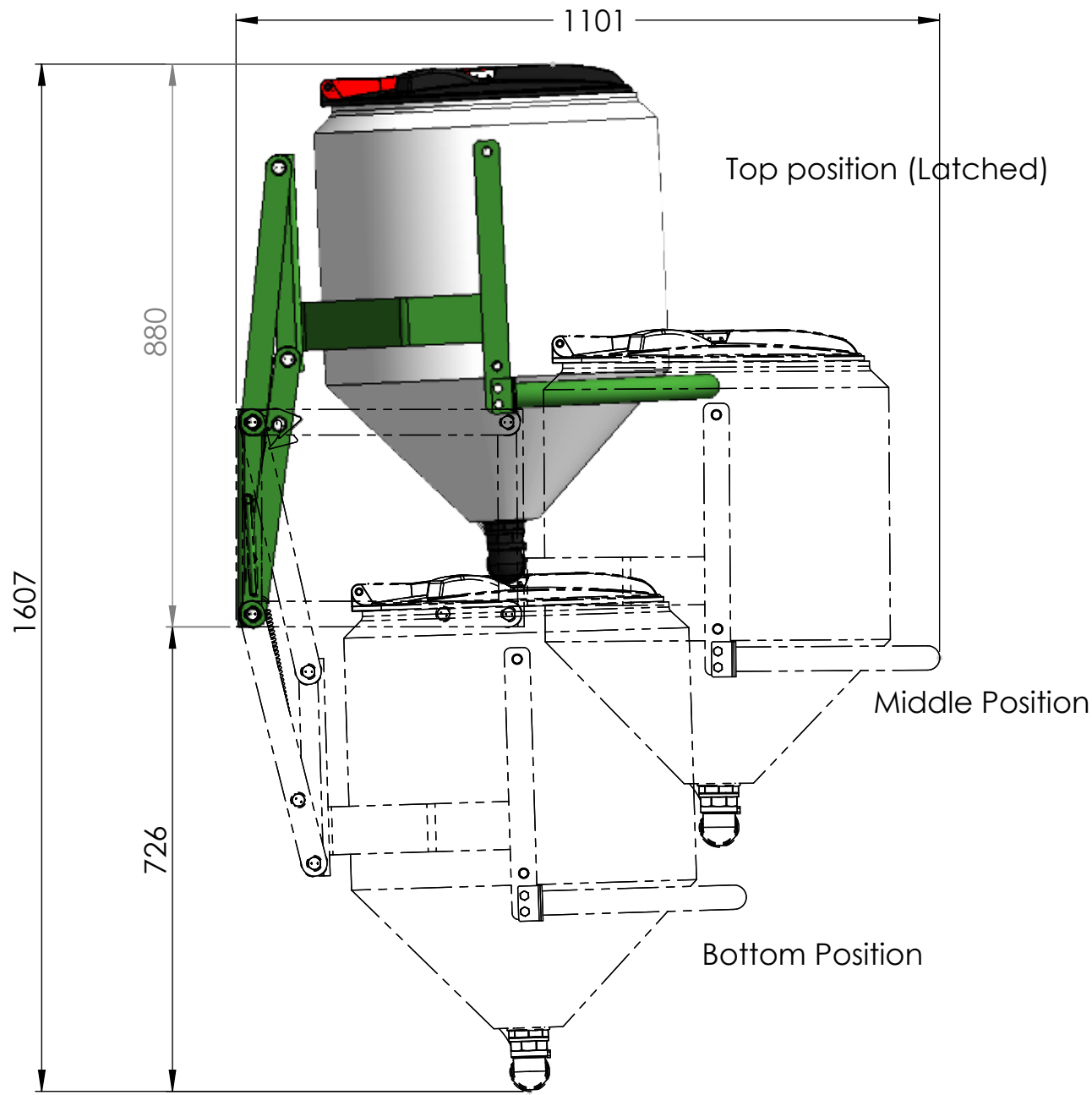

**TSI Beacon**  
TIME SAVER INDUSTRIES

PO BOX 16, BEACON WA 6472  
WEBSITE: [www.scudagcem.com.au](http://www.scudagcem.com.au)  
E-MAIL: [sales@scudagchem.com.au](mailto:sales@scudagchem.com.au)  
Mobile: 0428 861 119

THIS DRAWING AND ALL INFORMATION CONTAINED THEREON ARE THE EXCLUSIVE PROPERTY OF TSI BEACON.  
UNLESS SPECIFICALLY NOTED, THIS DRAWING AND ITEMS SHOWN ON THIS DRAWING ARE SUBJECT TO CHANGE AT ANY TIME.

MATERIAL:  
Material <not specified>  
WEIGHT: 29.0 kg

DESCRIPTION  
SCUD Tank 100 with DDL800

PART NUMBER  
ST100BHDL800

REV

DO NOT SCALE DRAWING SHEET 3 OF 3

6 5 4 3 2 1